

## 4-bar LED

**Ideal for commercial or industrial applications, Albeo's LED High Bay luminaire provides an energy efficient, no maintenance alternative to traditional light fixtures. Replaces up to 400W metal halide or up to eight (8) T8 lamps. Achieve 3 to 5 times longer life with Albeo's patent-pending TEMPR™ Technology. Heavy duty, instant start time, and no mercury.**

### Robust and Innovative Construction

Heavy duty extruded housing and Albeo's TEMPR™ thermal management technology transfers heat from the LED, reducing junction temperature for more light and longer life.

### Superior Performance

High performance LEDs offer superior efficacy and visual acuity with broad spectrum, quality colors. Instant start time. No flicker or buzzing. -30 to +45 C operating temperature.

### Optical Advantage

Directional LEDs put light where it's needed. Standard, narrow, or aisle lens available.

### Electrical System

120V, 277V, or 347V input. Variety of transformers available. Luminaire disconnect optional.

### Easy Mounting

Standard chain/cable or rod suspended.

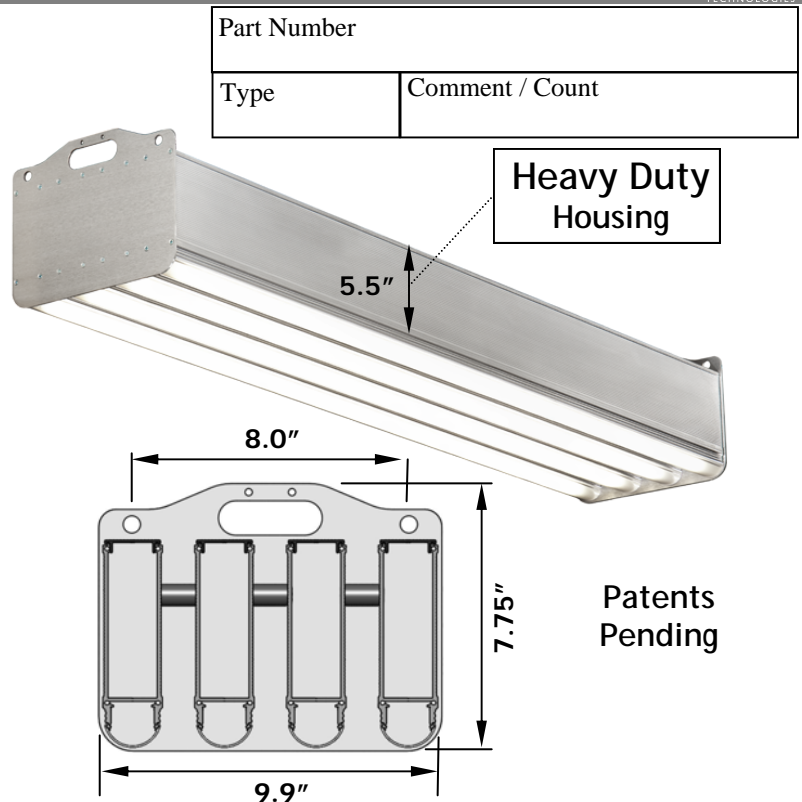

### Controls

Optimize energy savings with occupancy sensing and dimming options.

### Lifetime

Independently certified in-situ temperature testing in conjunction with LM-80 tested LEDs provides L70 lifetime up to 100,000 hours.

### Warranty

5 years, subject to Albeo's standard terms and conditions.

## Ordering Information

Not all combinations available. See chart on page 2.

Product Platform	Model	# of LED bars	Length	LED CCT	LED Pitch	Input Voltage	Optics	Mounting	Intelligent Controls	Revision
<b>HB</b>	<b>B</b>	<b>4</b>	<b>4</b>	<b>0</b>	<b>0</b>	<b>1</b>	<b>0</b>	<b>C</b>	<b>0</b>	<b>0</b>
HB LED High Bay Light Fixture	B High Brightness V High Value	4 4 bars 6 6 bars	4 4 ft	4 5000°K 5 4200°K	0 1 inch (Bright) 1 1.5 inch (Value)	1 120 V 2 277 V 3 347 V	0 Lens 1 No Lens N Narrow (44° beam) A Aisle (14° beam)	C Chain R Rod	0 None M Motion Sensor V 0-10V Dimming	Revision used to further define product configuration. See chart on page 2.

Made in America



LM-79 Tested

rev. 8.5.10

4-bar LED

Part Number	
Type	Comment / Count

## Optical and Electrical Specifications

All options not listed. Please contact sales for technical specs of other part numbers.

Type	Part Number	Transformer	Dimming	Color	Temp	CRI	# LEDs	Lumens	Lm/W	Watts	UL
Bright	HB-B444-0x0x0-16	Toroid	0-10V only	Bright	5000 K	70	180	12850	74	173	yes
	HB-B445-0x0x0-16	Toroid	0-10V only	Cool	4200 K	85	180	10620	61	173	yes
	HB-B444-0x0x0-17	Toroid	0-10V only	Bright	5000 K	70	180	15000	69	216	yes
	HB-B445-0x0x0-17	Toroid	0-10V only	Cool	4200 K	85	180	12400	57	216	yes

Power and light output can vary +/-10%

## Photometry

Tested to LM-79 standards. IES files available.

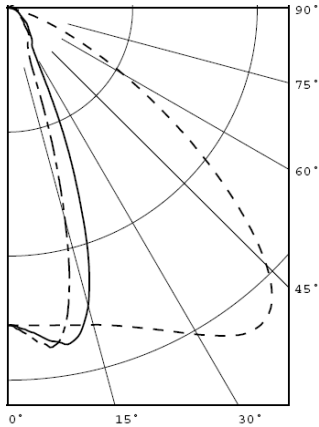

**Aisle Distribution**  
14° Beam Spread

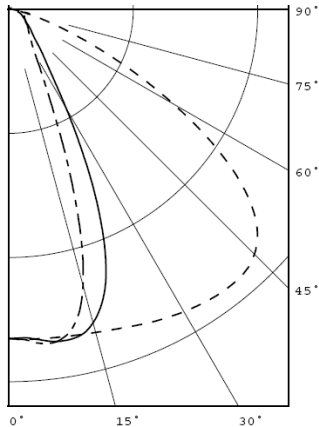

**Narrow Distribution**  
44° Beam Spread

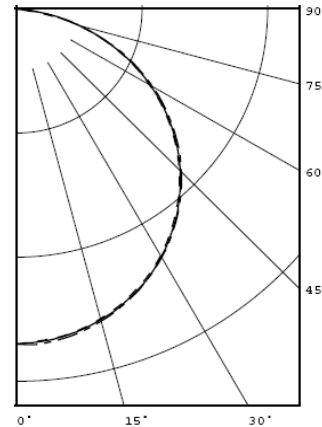

**Standard Distribution**  
120° Beam Spread

The Albeo LED High Bay fixture must be installed by a qualified electrician. It is the responsibility of the contractor, installer, purchaser, owner, and user to install, maintain, and operate the fixture in such a manner as to comply with all state and local laws, ordinances, regulations, and the American National Standards Institute Safety Code.

US Patents Pending

Specification subject to change without notice. See website for latest version.

Made in America



LM-79  
Tested

rev. 8.5.10